

1. The former pavement area of Area 1 retained for the drainage ditch drainage ditch.
2. The building area will have a sloped roof draining to parking or lawn.
3. The parking lot and walk will drain to lawn or Hoosick Street.

LEGEND

- Existing well construction to remain.
- New well construction
- (Elev) Finish elevation or grade.
- (ME) Taper grade, pavement, etc. to meet existing.
- Align finish edges
- Existing contour
- New contour
- Silk Fence
- Hydrogao
- L2 Hosts in mulch bed
- L3 Japanese Maple

KEYNOTES

- 0 No work, this area unless specifically directed by owner.
- 1 Not used
- 2 Remove building mounted devices and connections.
- 3 Remove pavement. Remove pavement as required for excavations, Patch / provide asphalt pavement edge. Tie to existing pavement, elevation, etc. as required.
- 4 Area of new asphalt paving. Match existing adjacent thickness, etc.
- 5 Area of new concrete sidewalk. See 4/S-11.
- 6 No Parking sign.
- 7 Handicap parking only sign.
- 8 Protect catch basins and inlets. Surround with hwy holes and provide fiber mesh screen. Clean regularly.
- 9 DEC wetlands delineation marker location.

3 RAMPED WALK DETAIL

1/4" = 1'-0"

RE-ISSUED 2/13/2020 FOR PLANNING REVIEW

2 DETAIL PLAN AT NEW BUILDING

1" = 16'-0"

New pavements, pavement markings, building, etc. to be at right angles to existing pavement markings to remain.

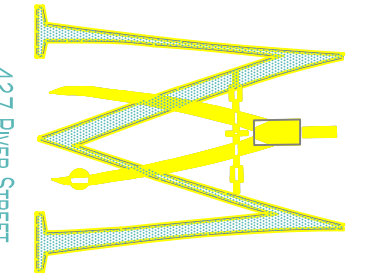
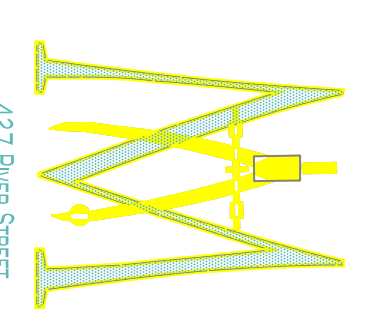

MICHAEL BRUNSWICK ACE HARDWARE
 ARCHITECTURAL SERVICES, PC
 427 RIVER STREET
 TRV, NEW YORK 12180 (518) 273-5120

MA # 017-018

DETAIL SITE PLANS AND DETAILS
 Renovate Rental Center with Addition
 831 Hoosick Street
 Brunswick, New York

DATE: February 13, 2020
REVISIONS:
 1 2/13/20
 2 2/13/20
 3 3/9/20
 4 5/6/20

SHEET: S-1.1
 (c) David Vignola/Vignola